



Swiss Conference on «Water and Light: Managing Strategies to Scale Up Sustainable and Environmental Projects in Colombia»

A transcultural view on scaling-up processes

Prof. Dr. Yvette Sánchez

University of St.Gallen on September 3 and 4, 2012.

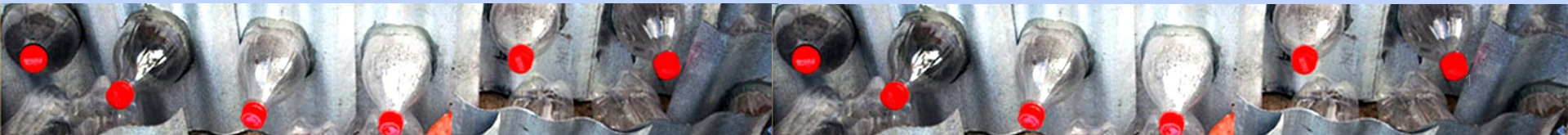

Strategic choices in scaling up

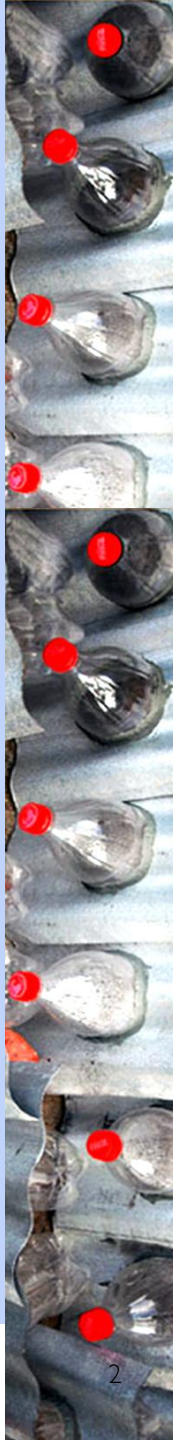

Cultural dimensiones

Hall	Hofstede	Trompenaars
contexto alto vs. contexto bajo	distancia al poder	colectivismo vs. individualismo
	individualismo vs. colectivismo	universalismo vs. particularismo
	masculinidad vs. feminidad	tiempo secuencial vs. sincrónico
orientación espacial	evasión de la incertidumbre	específico vs. difuso
	Orientación a largo plazo vs. orientación a corto plazo	rendimiento vs. origen
monocromo vs. policromo		control externo vs. control interno
		neutral vs. emocional

Ejemplos de dimensiones culturales en la investigación cultural comparativa (según Apfelthaler 1999).

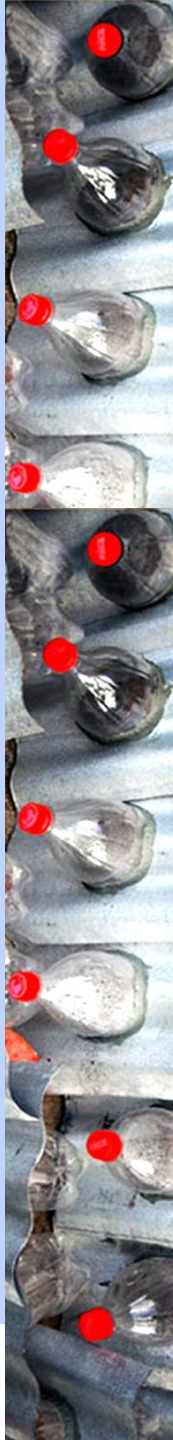

Cultural Dimensions: problems of this analytical instrument

- Stereotyping
- Cultural homogeneity is constructed
- Concentration on separating differences
- Static image of culture
- Reduction or simplification of national cultures
- Dynamics of organization processes are disregarded

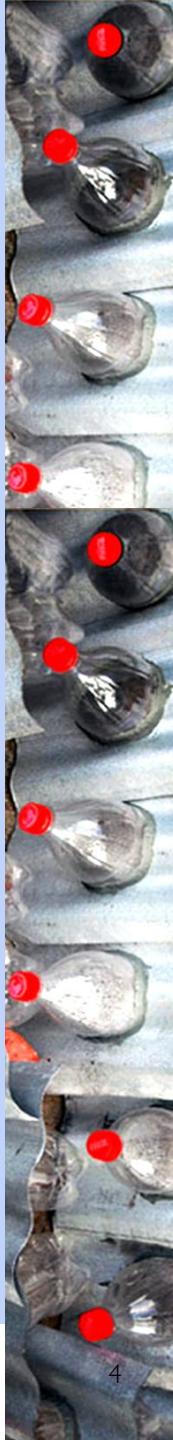

Innovation Funnel

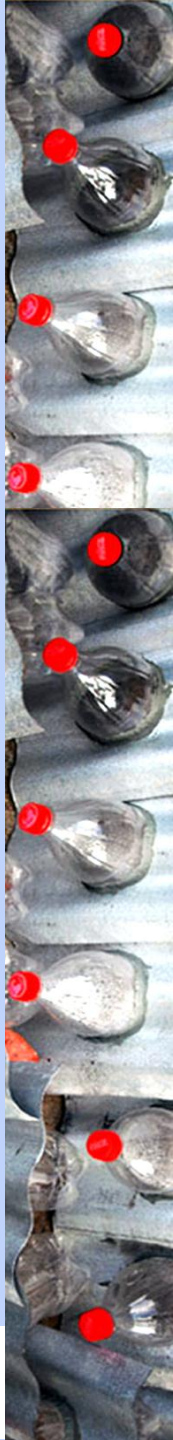
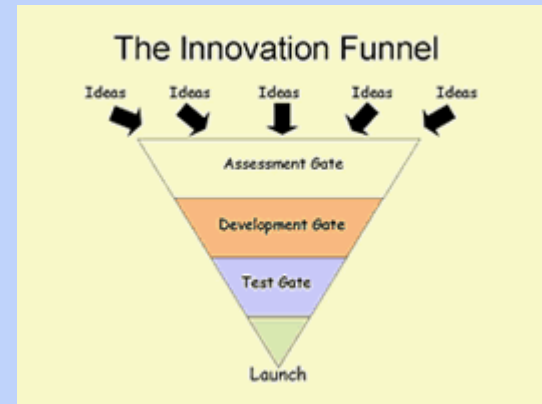
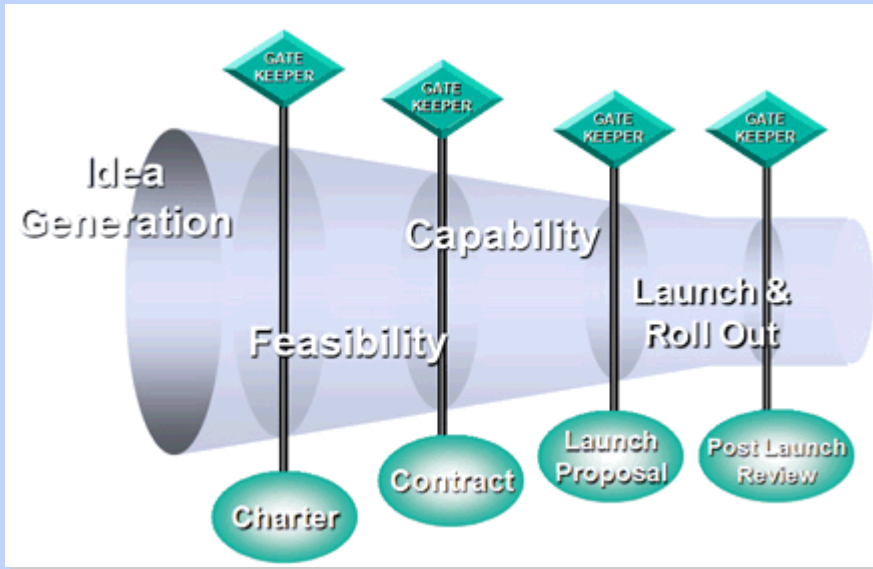

Waterfall model

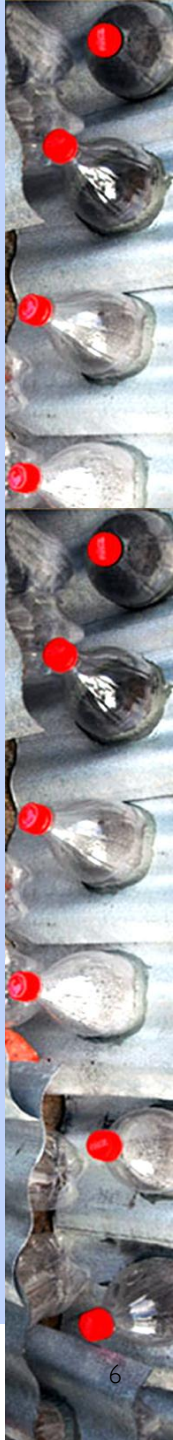
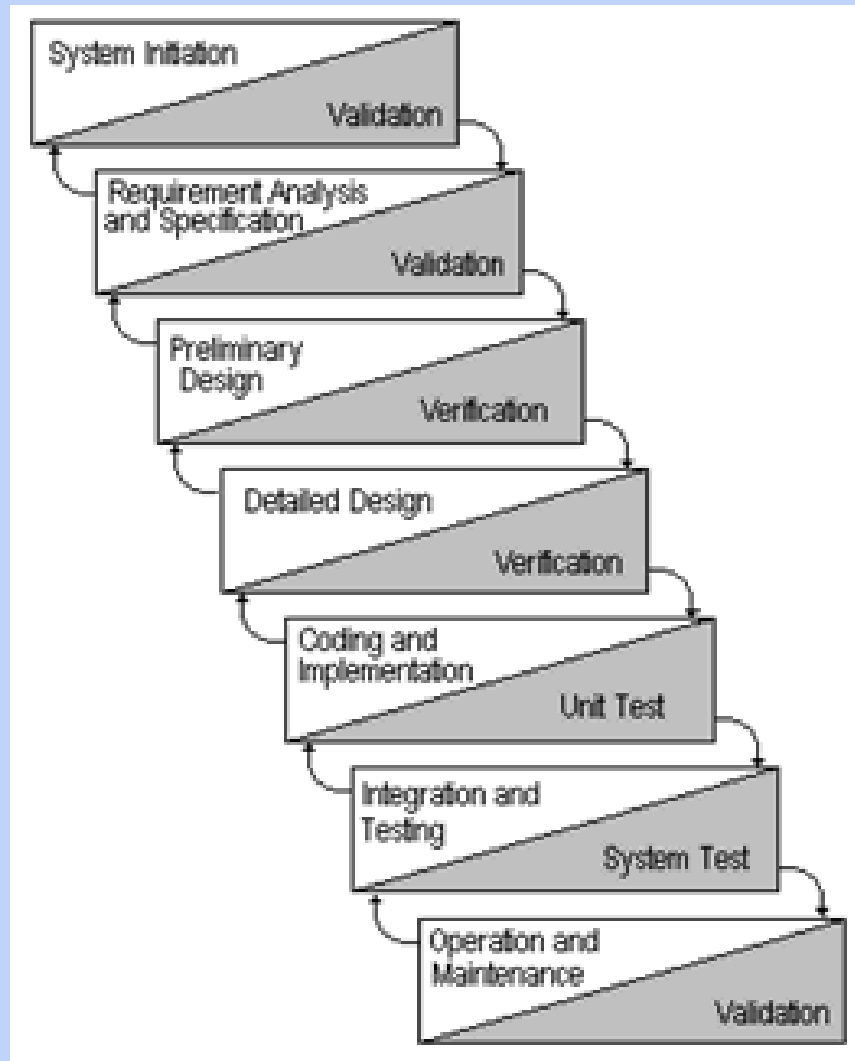

Spiral models

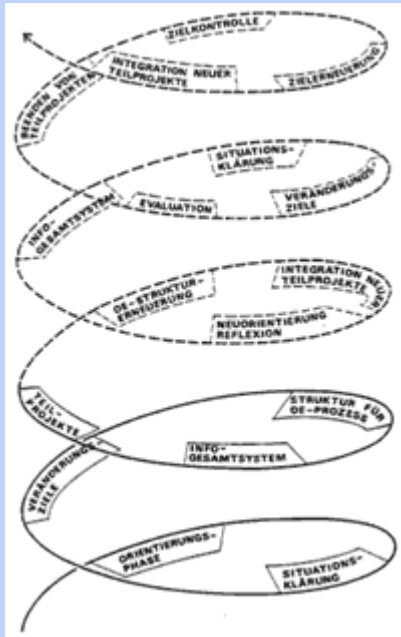

Spiral Dynamics

the eight-stage spiral of development

Search for "strong" values/DEES

What is interesting is that the psychology of the modern human being is an unfolding, emerging, unfolding, spiraling process, created by progressive recombination of ideas, from which behavior emerges in novel, higher-order systems.

Find the "subliminal" values/DEES

What is interesting is that the psychology of the modern human being is an unfolding, emerging, unfolding, spiraling process, created by progressive recombination of ideas, from which behavior emerges in novel, higher-order systems.

© Erich Schaefer

Spirale – Symbol der Seelenreise

Krisenverarbeitung als gesellschaftliche Interaktion

© Erich Schaefer

Was ist eigentlich bei ...?

Eingangs-Stadium I
begreifbar, handlungsweis Dimension

Durchgangs-Stadium II
emotional, erfahrungswerte Dimension

Ziel-Stadium III
reflexiv-kritisch, selbstregulierende Dimension

© Erich Schaefer

Wiederentdeckung der Liebe lebendig in Kairo, Frankfurt & Regensburg, 12. April 2002 – Ausgewandert und Literarisch
Krisen-Management in der Betriebswirtschaft – © 2002
Band 1: Begreifbare Erfahrung und selbstregulierende Theorie
Band 2: Selbstregulierung in Krisenverarbeitung
2002 – von Schaefer-Verlag – ein für alle Zeiten bestimmt

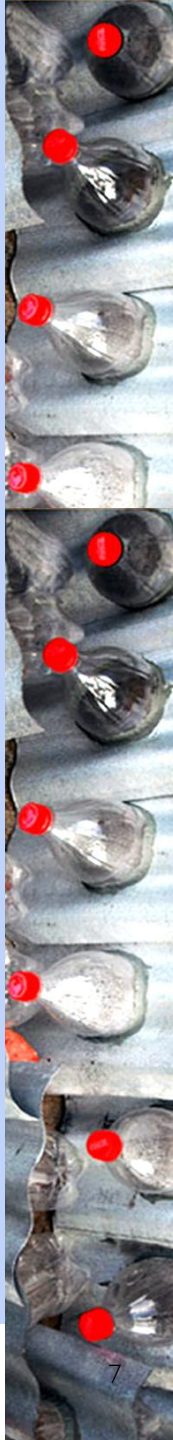

Fractals

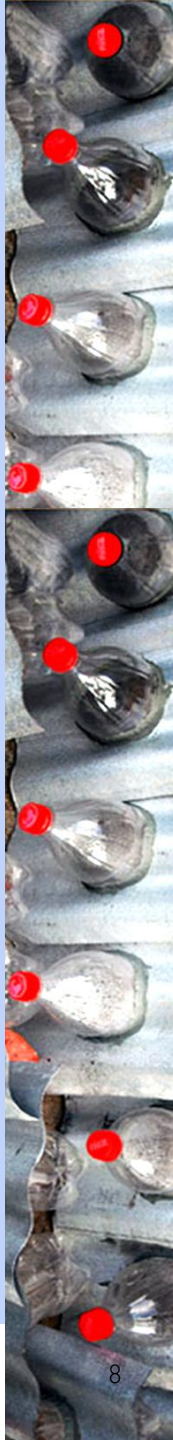
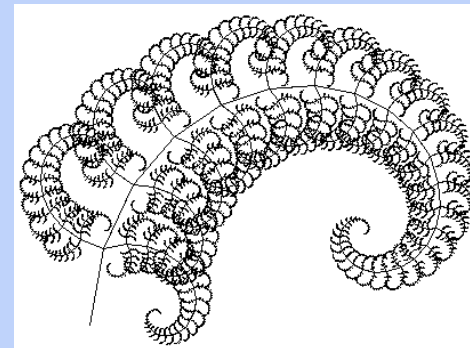
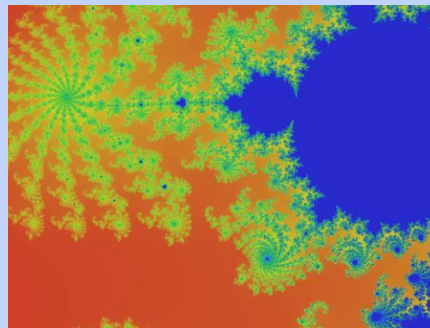
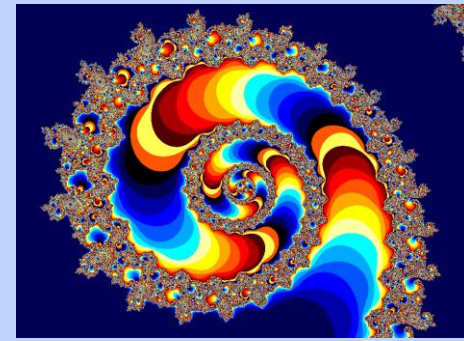

Interface

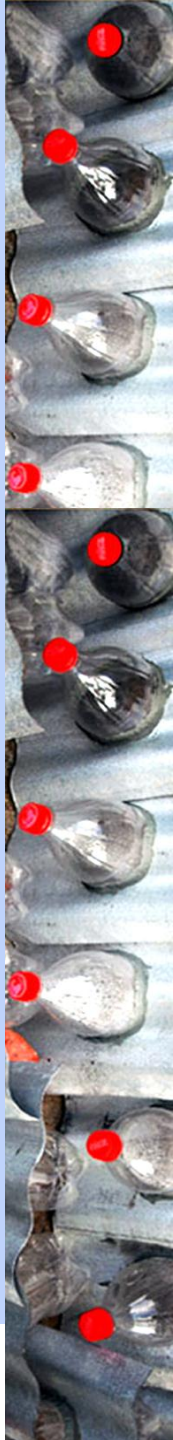
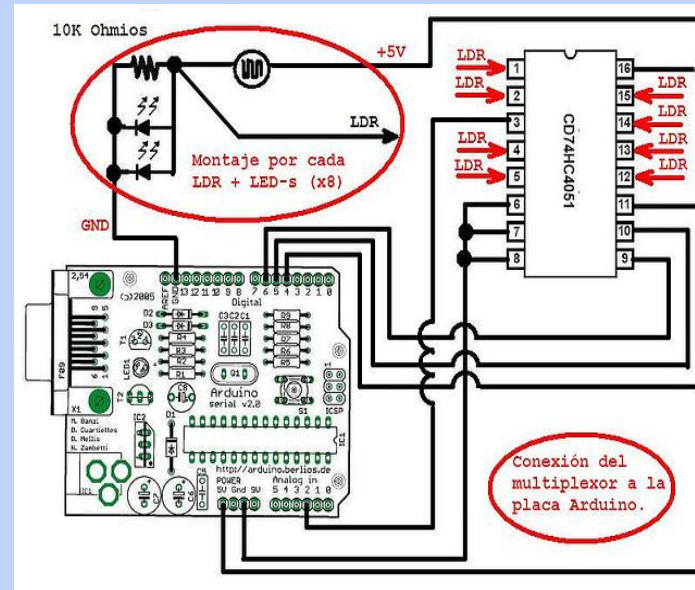
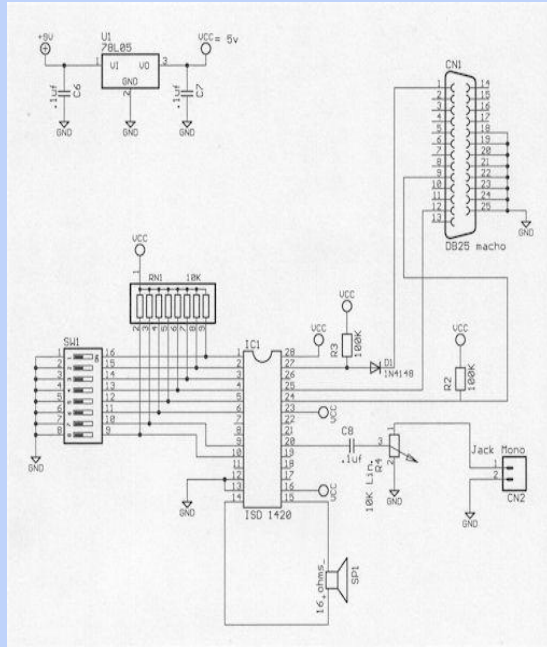

Rhizome/Mangrove

